

Design Equations—Commonly Used Amplifier Configurations

Voltage Follower

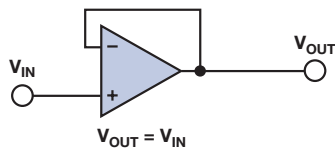

**BUFFER HIGH IMPEDANCE SOURCE
TO LOW RESISTANCE LOAD**

Noninverting Op Amp

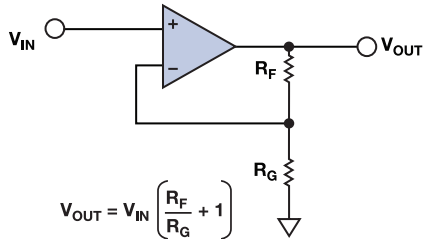

IN-PHASE SIGNAL AMPLIFICATION

Inverting Op Amp

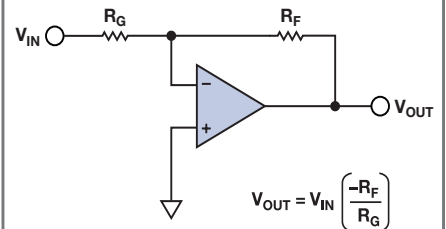

AMPLIFY AND INVERT INPUT

**Voltage Subtractor/
Difference Amplifier**

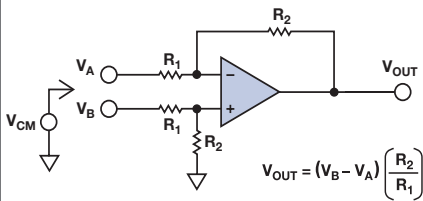

**AMPLIFY THE DIFFERENCE
BETWEEN TWO VOLTAGES,
REJECT COMMON-MODE VOLTAGE**

Voltage Adder

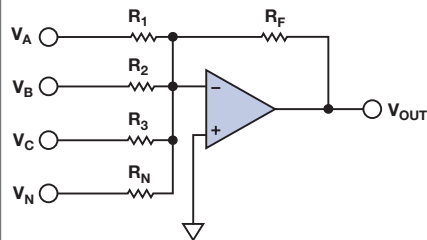

SUM MULTIPLE VOLTAGES

Low-Pass Filter/Integrator

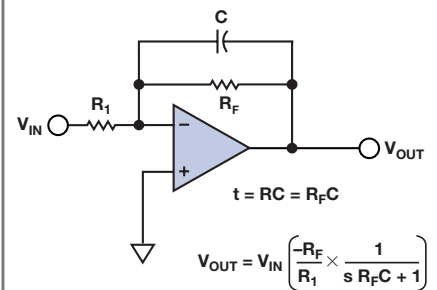

LIMIT BANDWIDTH OF SIGNAL

High-Pass Filter/Differentiator

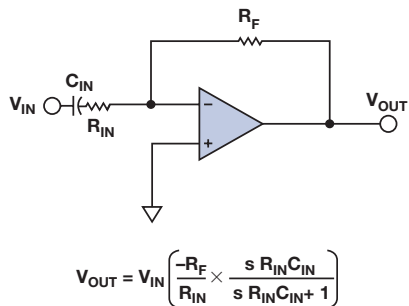

BLOCK DC, AMPLIFY AC

Differential Amplifier

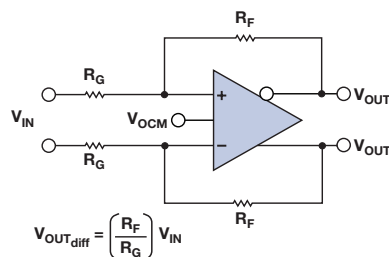

**DRIVE A DIFFERENTIAL INPUT ADC FROM A
DIFFERENTIAL OR SINGLE-ENDED SOURCE**

Instrumentation Amplifier

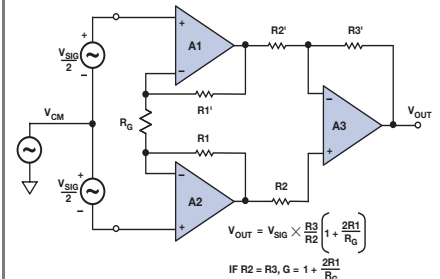

**AMPLIFY LOW LEVEL DIFFERENTIAL SIGNAL,
REJECT COMMON-MODE SIGNAL**

Op Amp Noise for Single-Pole System

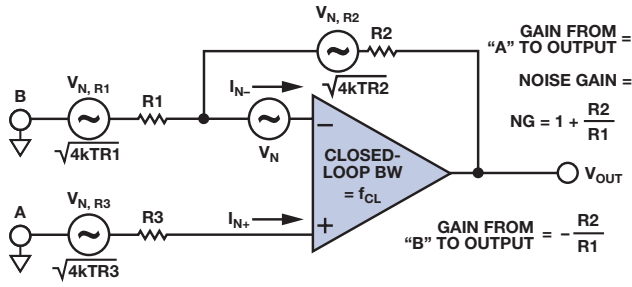

$$RTI \text{ NOISE} = \sqrt{BW} \times \sqrt{V_N^2 + 4kTR3 + 4kTR1 \left(\frac{R2}{R1 + R2}\right)^2 + I_{N+}^2 R3^2 + I_{N-}^2 \left(\frac{R1 \times R2}{R1 + R2}\right)^2 + 4kTR2 \left(\frac{R1}{R1 + R2}\right)^2}$$

RTO NOISE = NG × RTI NOISE
RTI = REFER TO INPUT
RTO = REFER TO OUTPUT

BW = 1.57 f_{CL}

Decibel (dB) Formulas (Equal Impedances)

$$db = 10 \text{ Log } \frac{P_{OUT}}{P_{IN}} = 20 \text{ Log } \frac{V_{OUT}}{V_{IN}}$$

$$= 20 \text{ Log } \frac{I_{OUT}}{I_{IN}} \text{ (Gain)}$$

$$db = 10 \text{ Log } \frac{P_{IN}}{P_{OUT}} = 20 \text{ Log } \frac{V_{IN}}{V_{OUT}}$$

$$= 20 \text{ Log } \frac{I_{IN}}{I_{OUT}} \text{ (Gain)}$$

Sinusoidal Voltages and Currents

RMS = Root Mean Square = Effective

V_{rms} = 0.707 V_{PEAK}

V_{AVE} = 0.637 V_{PEAK}

V_{PEAK} = 1.414 V_{EFF}

V_{EFF} = 1.11 V_{AVE}

V_{PEAK} = 1.57 V_{AVE}

V_{AVE} = 0.9 V_{EFF}

Resistor Johnson Noise Formula

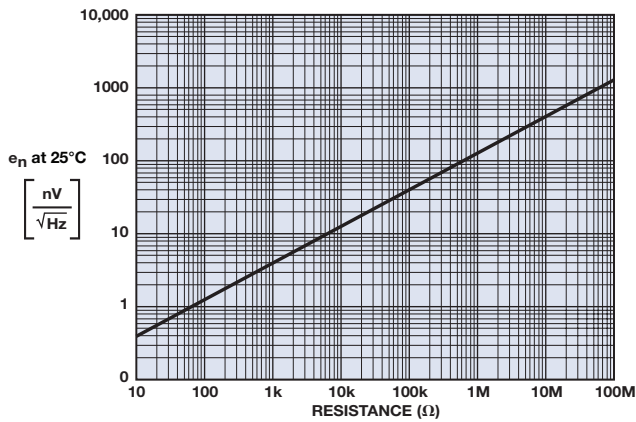

$V_R = \sqrt{4kTRB}$

where:

V_R = resistor Johnson Noise spectral density

k = Boltzmann's constant (1.38 × 10⁻²³ J/K)

T = absolute temperature in Kelvin

R = resistance in Ohms

B = bandwidth in Hz

At 25°C, 4kT = 1.65 × 10⁻²⁰ W/Hz, therefore, V_R = √(1.65 × 10⁻²⁰RB)

Ohm's Law (DC Circuits)

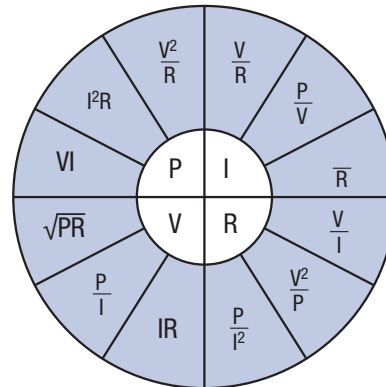

Resistors in Series

R_{TOTAL} = R₁ + R₂ + R₃ + ...

Resistors in Parallel

$$R_{TOTAL} = \frac{1}{\frac{1}{R_1} + \frac{1}{R_2} + \frac{1}{R_3} + \dots}$$

Two Resistors in Parallel

$$R_{TOTAL} = \frac{R_1 R_2}{R_1 + R_2}$$

Equal Resistors in Parallel

R_{TOTAL} = $\frac{R}{N}$ Where R is the value of one of the equal resistors, and N is the number of equal resistors

Closed-Loop Frequency Response for Voltage Feedback Amplifiers

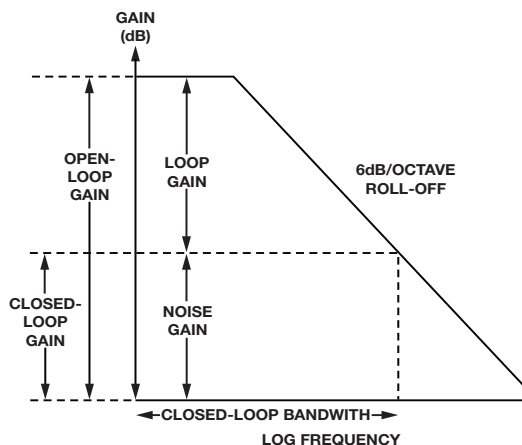

Reactance Formulas

$$X_C = \frac{1}{2\pi fC}$$

$$X_L = 2\pi fL$$

Impedance Formulas (Series)

$$Z = \sqrt{R^2 + X_L^2} \text{ (Series RL)}$$

$$Z = \sqrt{R^2 + X_C^2} \text{ (Series RC)}$$

$$Z = X_L - X_C \text{ (Series LC)}$$

$$Z = \sqrt{R^2 + (X_L - X_C)^2} \text{ (Series RLC)}$$

$$Z = \frac{V_A}{I}$$

Voltage and Impedance Formulas (Parallel)

$$Z = \frac{RX_L}{\sqrt{R^2 + X_L^2}} \text{ (RL)} \quad Z = \frac{V_A}{I_{LINE}}$$

$$Z = \frac{RX_C}{\sqrt{R^2 + X_C^2}} \text{ (RC)} \quad V_A = V_L = V_C = V_R$$

$$Z = \frac{X_L X_C}{X_L - X_C} \text{ (LC)} \quad V_A = I_{LINE}Z$$

$$Z = \frac{RX}{\sqrt{R^2 + X^2}} \text{ (RLC)}$$

Transformers (Step-Up or Step-Down Ratios)

$$\frac{N_p}{N_s} = \frac{E_p}{E_s} = \frac{I_s}{I_p} = \sqrt{\frac{Z_p}{Z_s}}$$

Common 1% Resistor Values

1% standard values decade multiples are available from 10.0 through 1.00 M (also 1.10 M, 1.20 M, 1.30 M, 1.50 M, 1.60 M, 1.80 M, 2.00 M, and 2.20 M). Standard base resistor values are given in the following table for the most commonly used tolerance (1%), along with typically available resistance ranges. To determine values other than the base, multiply the base value by 10, 100, 1000, or 10,000.

10.0	10.2	10.5	10.7	11.0	11.3	11.5	11.8	12.1	12.4	12.7	13.0
13.3	13.7	14.0	14.3	14.7	15.0	15.4	15.8	16.2	16.5	16.9	17.4
17.8	18.2	18.7	19.1	19.6	20.0	20.5	21.0	21.5	22.1	22.6	23.2
23.7	24.3	24.9	25.5	26.1	26.7	27.4	29.0	28.7	29.4	30.1	30.9
31.6	32.4	33.2	34.0	34.8	35.7	36.5	37.4	38.3	39.2	40.2	41.2
42.2	43.2	44.2	45.3	46.4	47.5	48.7	49.9	51.1	52.3	53.6	54.9
56.2	57.6	59.0	60.4	61.9	63.4	64.9	66.5	68.1	69.8	71.5	73.2
75.0	76.8	78.7	80.6	82.5	84.5	86.6	88.7	90.9	93.1	95.3	97.6

Common Capacitor Values

pF	pF	pF	pF	μF	μF	μF	μF	μF	μF	μF
1.0	10	100	1000	0.01	0.1	1.0	10	100	1000	10,000
1.1	11	110	1100							
1.2	12	120	1200							
1.3	13	130	1300							
1.5	15	150	1500	0.015	0.15	1.5	15	150	1500	
1.6	16	160	1600							
1.8	18	180	1800							
2.0	20	200	2000							
2.2	22	220	2200	0.022	0.22	2.2	22	220	2200	
2.4	24	240	2400							
2.7	27	270	2700							
3.0	30	300	3000							
3.3	33	330	3300	0.033	0.33	3.3	33	330	3300	
3.6	36	360	3600							
3.9	39	390	3900							
4.3	43	430	4300							
4.7	47	470	4700	0.047	0.47	4.7	47	470	4700	
5.1	51	510	5100							
5.6	56	560	5600							
6.2	62	620	6200							
6.8	68	680	6800	0.068	0.68	6.8	68	680	6800	
7.5	75	750	7500							
8.2	82	820	8200							
9.1	91	910	9100							